



WARP KNITTING  
经编机

## HKS 4-M ON

## High-performance tricot machine with the most flexibility 极具灵活性的高性能特里科经编机

### Your benefit

- The HKS 4-M ON is particularly characterized by its high flexibility and efficiency
- New advantages through connectivity, new patterning systems and state-of-the-arts control system KAMCOS 2
- The Spring Motion Assistant allows a quick, easy and safe change of guide bars without tools
- Create your own lappings without the limitation to 36 stitches for more flexibility and innovation with k.innovation CORE and CORE lite
- Improved warp beam support – easy and safe access to warp beam clamping positions through moveable ladders with multiple connecting positions on the front side of the machine and additional platform on the right side of the machine.
- Direct drive system for improved maintenance costs and less energy consumption
- Adjustable yarn tension spring – the stiffness of the tension rails can be easily adjusted to improve handling of the machine and fabric quality without changing the tension springs

### 您的优势

- HKS 4-M ON的特点是高度的灵活性和效率
- 通过连接性、全新的花型系统和最先进的卡迈酷斯®2控制系统带来全新的优势
- 梳栉拆卸辅助系统无需工具即可快速、轻松、安全地更换梳栉
- 借助k.innovation CORE和CORE lite (基础版) 创建花型, 将会突破36横列的花型限制, 从而获得最高的灵活性和创新性
- 改进后的经轴架, 可以通过机器前面多个可移动的楼梯连接点和机头额外的平台边界安全地进入锁紧经轴的操作位置
- 直接驱动系统用于优化维护成本, 降低能耗
- 可调节纱线张力弹簧——张力杆的刚度可以轻松调节, 以提高机器的操控性和织物质量, 无需更换张力弹簧

# HKS 4-M ON

## Technical data

### 技术参数

#### Working width / Gauge

130" (+6" working width extension), 180" (+6" working width extension), 210" (+8" working width extension), 260" (+8" working width extension) E 28, E 32

#### Bars / knitting elements

Individual needle bar (synchronously milled), tongue bar (synchronously milled), sinker bar with knockover adjustment (chromium-plated sinkers), four ground guide bars (GB 1 up to GB 4 stitch-forming, shog up to 50 mm). All the bars are made of carbon fiber reinforced plastic.

#### Warp beam support

Free-standing – four warp beam positions for sectional beams of 812 mm (32") flange diameter and having a length of 540 mm (21,3") or 1090 mm (42,9"), pre-assembled for despatch in containers. Optional: Warp beam support 4x40"

#### KAMCOS® 2 (KARL MAYER COMMAND SYSTEM)

Enlarged patterning possibilities by means of Multi Speed. Depending on the relevant pattern to be worked, it might be necessary to reduce the production speed during sequential operation.

#### Integrated monitoring systems

- Integrated Lightning
- Integrated Laserstop
- Integrated Camera

#### Pattern drive – ON

Pattern data to be downloaded from KARL MAYER cloud via k.ey (not included). Spring motion assistant for quick, easy and safe guide bar change.

#### Operation platform

Platform on the right side of the machine for easier handling of the warp beams.

#### Batching device No. 6

Central batcher, max. batch diameter of 736 mm (29 inches), driven by the machine; fabric tension is adjustable via sliding clutch (130 – 210 inches).

#### Batching device No. 34B

Standing separately, with friction drive, max. batch diameter of 914 mm (36 inches), driven by geared motor with integrated frequency converter, control to match the stitch courses, driving roller and carrier roller of 118.6 mm diameter, coated with black grip tape, two deflection rollers of 70 mm diameter without coating, connected load 1 kVA. (260 inches)

#### Fabric take-up

Electronically controlled fabric take-up, driven by geared motor, consisting of four rollers (roller A = 156,6 mm + rollers B and C = 118,6 mm + roller D = 55,6 mm); all rollers in continuous execution; rollers A, B, C and D coated with black grip tape

#### Oil supply

Heating, cooling by means of recirculating-air heat exchanger, circulation by means of electric pump, filter with dirt-monitoring system.

#### 工作门幅 / 机号

130" (+ 2"工作门幅), 180" (+ 6"工作门幅), 210" (+ 8"工作门幅), E 28, E 32  
260" (+ 8"工作门幅), E 28, E 36

#### 床体/成圈机件

同步铣削的嵌入式针床和针芯床, 脱圈深度可调的沉降片床(镀铬的沉降片), 四把地梳(GB 1到GB 4可成圈), 累积横移距离达到50 mm。所有床身均采用碳纤维增强塑料。

#### 经轴架

独立式, 4 × 312 mm (法兰盘直径为32英寸), 外档宽度为540 mm (21.3英寸) 或1090 mm (42.9英寸), 为适应集装箱运输而预先组装。  
选配: 4 × 40"经轴架

#### 卡迈酷斯®2 (卡尔迈耶控制系统)

通过多速送经, 扩大了花型可能性。在连续操作中有必要降低生产速度, 取决于执行的相关花型。

#### 配套监控系统

- 集成式照明系统
- 集成式激光自停装置
- 集成式照相自停装置

#### 提花机构——ON

通过k.ey (不包括) 可以从卡尔迈耶云端下载花型数据。梳栉拆卸辅助系统可快速、简便、安全地更换梳栉

#### 操作平台

方便对经轴进行操作, 包括更换盘头、维护、处理纱线等

#### 6号卷布机

轴心卷取, 最大卷取直径为736 mm (29英寸), 由机器驱动; 织物张力可通过摩擦片进行调节 (130–210英寸)

#### 34B号卷取机构

落地式, 摩擦传动的卷取机构, 由带有集成式变频器的电机驱动。根据线圈密度进行调节, 驱动罗拉和承载罗拉的直径为118.6 mm, 均包裹黑色包布。两个导布辊直径70 mm, 无涂层, 连接负载1千伏安 (260英寸)

#### 织物牵拉机构

电子控制, 4罗拉系统由电机驱动 (罗拉A = 156,6 mm + 罗拉B罗拉C = 118,6 mm + 罗拉D = 55,6 mm); 所有罗拉联动运转, 均包裹黑色包布

#### 供油

加热装置, 通过空气流通式热交换装置冷却, 通过电泵实现循环, 曲柄连杆加压润滑, 配备脏脏报警过滤器

#### 终端用途

内饰织物, 刺绣基底+薄纱, 运动装, 鞋材, 汽车内饰, 旗帜+印花基底, 外套

#### End uses

Upholstery, embroidery ground + tulle, sportswear, shoe fabric, automotive interior, flag banner + printing ground, outerwear

#### 终端用途

内饰织物, 刺绣基底+薄纱, 运动装, 鞋材, 汽车内饰, 旗帜+印花基底, 外套

#### Height and depth / 高度和纵深

4 × 812 mm (32 英寸) ∅

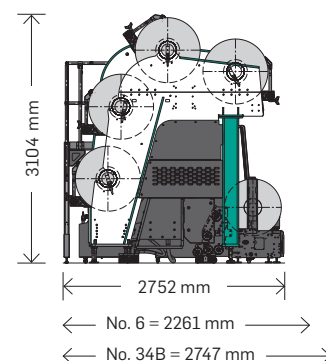

#### Total width 宽度

8787 mm

#### Total depth 纵深

2752 mm

#### Total height 高度

3104 mm